

CAVALERIE

BICYCLE MANUFACTURER



ANNOUNCING
V1



Contents

-Riding safely	<i>Page 3</i>
-Frame sizing	<i>Page 4</i>
-Geometry	<i>Page 5</i>
-Standard build	<i>Page 6</i>
-Transmission chart	<i>Page 7</i>
-Wheel assembly/disassembly	<i>Page 8</i>
-Frame torque setting	<i>Page 9</i>
-Cable routing	<i>Page 10</i>
-Sprocket replacement	<i>Page 11</i>
-Rear wheel tension	<i>Page 13</i>
-Shifter setup / cable replacement	<i>Page 14</i>
-Maintenance	<i>Page 15</i>
-Modular build	<i>Page 17</i>
-Warranty	<i>Page 18</i>



Equipment

According to the CPSC and CE norms, wearing a helmet is mandatory. We recommend that you wear a full-face helmet for gravity riding.

In case of a fall, not having a helmet on can lead to serious injuries or even death.

We also advise riders to wear knee pads and a back protector. These items can reduce injuries caused by falls.

Riding

Riding on rough grounds may result in damages to the tires and more globally to the bike itself.

When riding at night or in low light, front and rear lights are mandatory.

On wet, snowy, or dry ground, the adherence is worse and can lead to falls and injuries.

Riding with great speed, on rough grounds, and/or with mandatory jumps increases the risk of injuries.

Terms of use

-Failure to comply with advised torques on screws may result in damages on the bike parts, and will put your safety at risk.

-After every fall, check frame welds, and the bike's proper functioning.

-Do not allow mechanical play on the bike. A persisting play can lead to breaks on some components and put your safety at risk.

-Do not take off the plastic cover on the gearbox's output side to avoid leg injuries.

-Exposure to temperatures higher than 70°C/158°F will damage some parts of the bike, and alter the mechanical properties of the frame.

-The use of the bike apart from the described conditions can deteriorate the bike or some of its components.

-Our bikes are designed to withstand a rider's weight of 100kg. The use of the bike by someone above the weight limit will result in warranty restrictions.



Frame sizing

1m60

1m70

1m80

1m90

2m00

Size M

Size L

Size XL

Not suitable

Moderately suitable

Suitable

Perfectly suitable



CAVALERIE
BICYCLE MANUFACTURER



Geometry

Anakin V2 full 29" 160/158mm

		M	L	XL
1	Seat tube lenght	432	432	432
2	STA	77,5°	77,5°	77,5°
3	HTA	64.3°	64.3°	64.3°
4	Wheelbase	1228	1257	1284
5	Top tube lenght	602	629	654
6	Chainstay	425-439	425-439	425-439
7	BB drop	-30	-30	-30
8	Reach	453	478	503
9	Stack	634	642	642

Anakin V2 Mullet 180/176mm

		M	L	XL
1	Seat tube lenght	430	430	430
2	STA	76.8°	76.8°	76.8°
3	HTA	63.5°	63.5°	63.5°
4	Wheelbase	1236	1266	1293
5	Top tube lenght	597	624	649
6	Chainstay	422-436	422-436	422-436
7	BB drop	-28	-28	-28
8	Reach	449	474	499
9	Stack	648	656	656

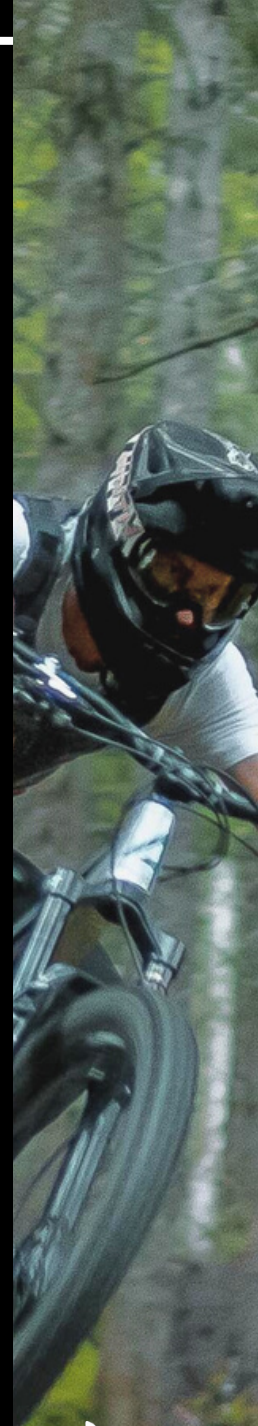
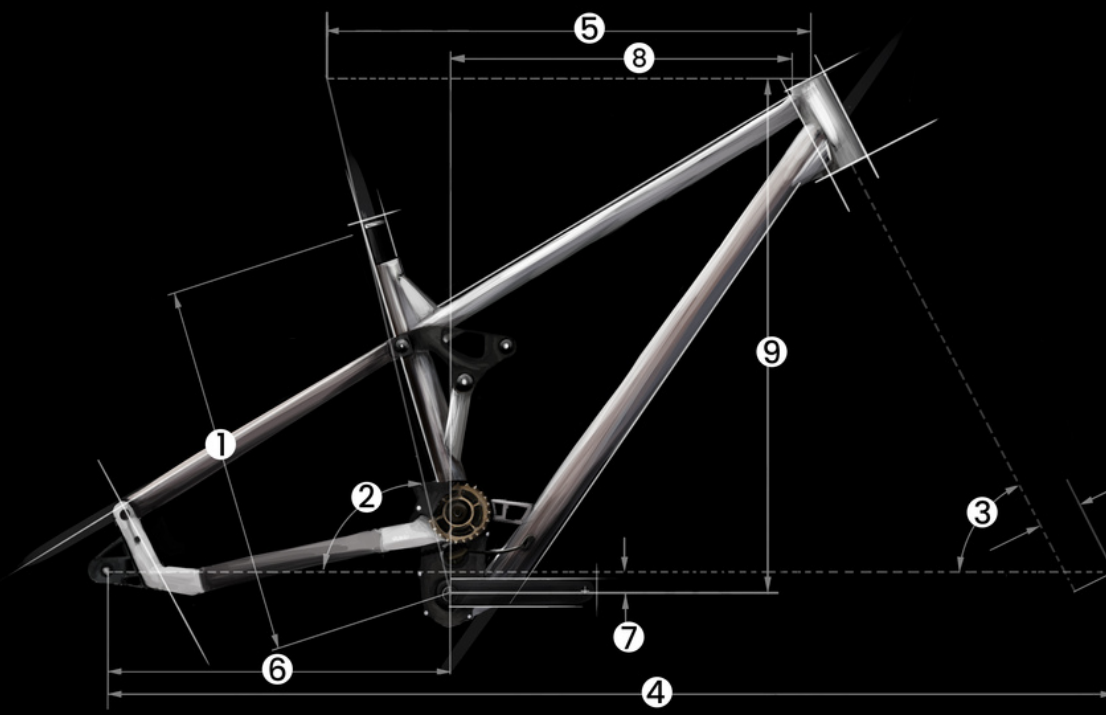

CAVALERIE
BICYCLE MANUFACTURER

Assembly

Shock	Trunion 205x65 -> 205x57.5	
Seat tube max insertion	Ø31.6 x max 266 mm	
Seat tube min insertion	150 mm	
Headset	ZS44 - ZS56	
Cranks	Isis print / 170 - 155mm	
Rear wheel hub	Boost 12 x 148	
Disc size	203/180 front	180 rear (203 depending on calipers)



Risk of cracks on the frame otherwise

Assembly tips

Front and rear travel	Wheel		
	29"-29"	Mullet	27.5"-27.5"
160-158	Highly recommended	Recommended	Impossible
170-158	Highly recommended	Recommended	Not recommended
170-164	Recommended	Highly recommended	Not recommended
170-170	Possible	Highly recommended	Possible
180-176	Not recommended	Highly recommended	Recommended
200-176	Not recommended	Recommended	Highly recommended

	Impossible
	Not recommended
	Possible
	Recommended
	Highly recommended



Warranty will not apply to assemblies not listed in this chart.



Transmission chart

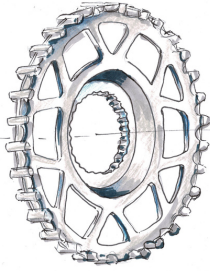

Belt

Front sprocket	Rear sprocket	Ratio	Belt length	Base 27.5"	Base 29"
24	34	0.71	111	432.5	436
22	32	0.69	108	427	430.5
26	39	0.67	113	424	
24	39	0.62	113	429.5	433
22	39	0.56	111	423.5	

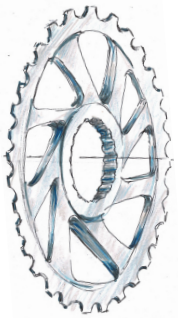

Chain

Front sprocket	Rear sprocket	Ratio	Chain length	Base 27.5"	Base 29"
20	26	0.7	94	432.5	436
20	28	0.65	98	426	429.5
20	30	0.61	96	430.5	433.9
22	34	0.59	98	424.5	
20	32	0.57	96	424.5	
22	36	0.56	100		433.5

Comparing with Sram Eagle Cassette 10-50

Sprocket	Ratio
34	0.68
32	0.64
30	0.6
28	0.56

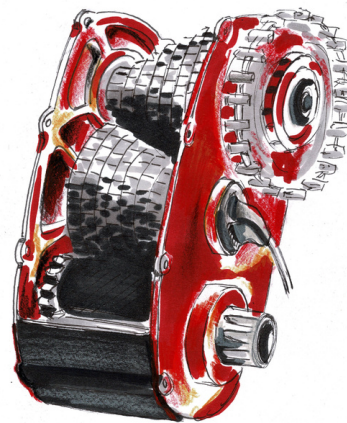
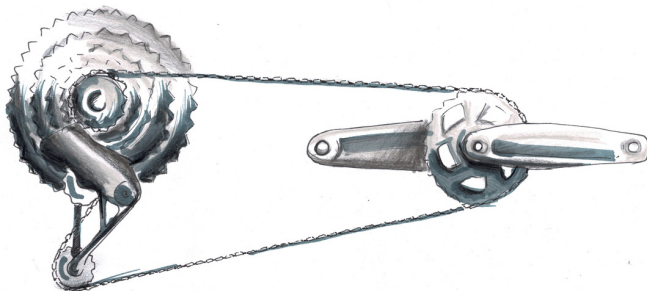

CAVALERIE
BICYCLE MANUFACTURER

Front wheel disassembly

Disassemble using an Allen key or the axle's handle. You must rotate anti-clockwise.

When re-assembling the wheel, follow the constructor's guide on tightening the axle. A poorly tightened wheel can cause serious injuries.



Rear wheel disassembly

Using a size 6 Allen key or a size 14 wrench, rotate anti-clockwise to unscrew the rear axle.

Always take off the belt or chain after removing the axle.

To re-assemble the rear wheel, apply a torque of 10 Nm.

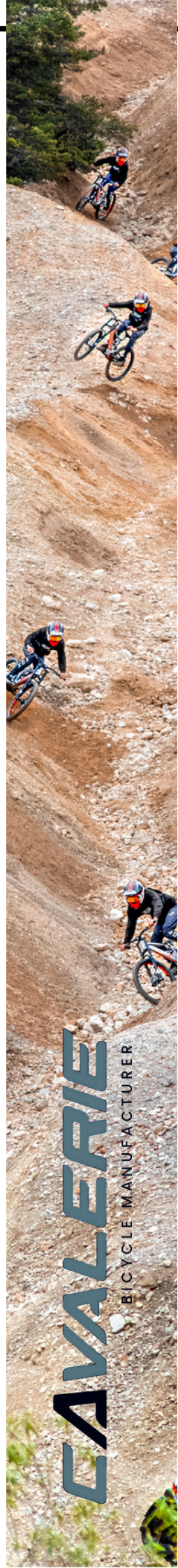
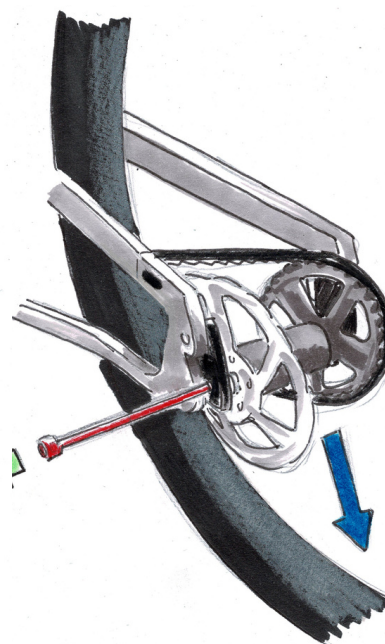
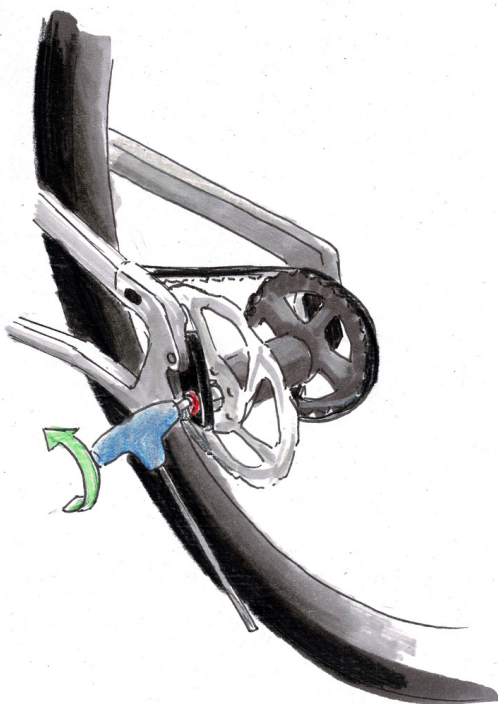

Frame torque setting

Please apply these following torques.

Overtightening screws and bolts can cause damage, break it or block the assembly.

Undertightening can lead to screws becoming loose.

Not following the tightening torques may result in serious injuries

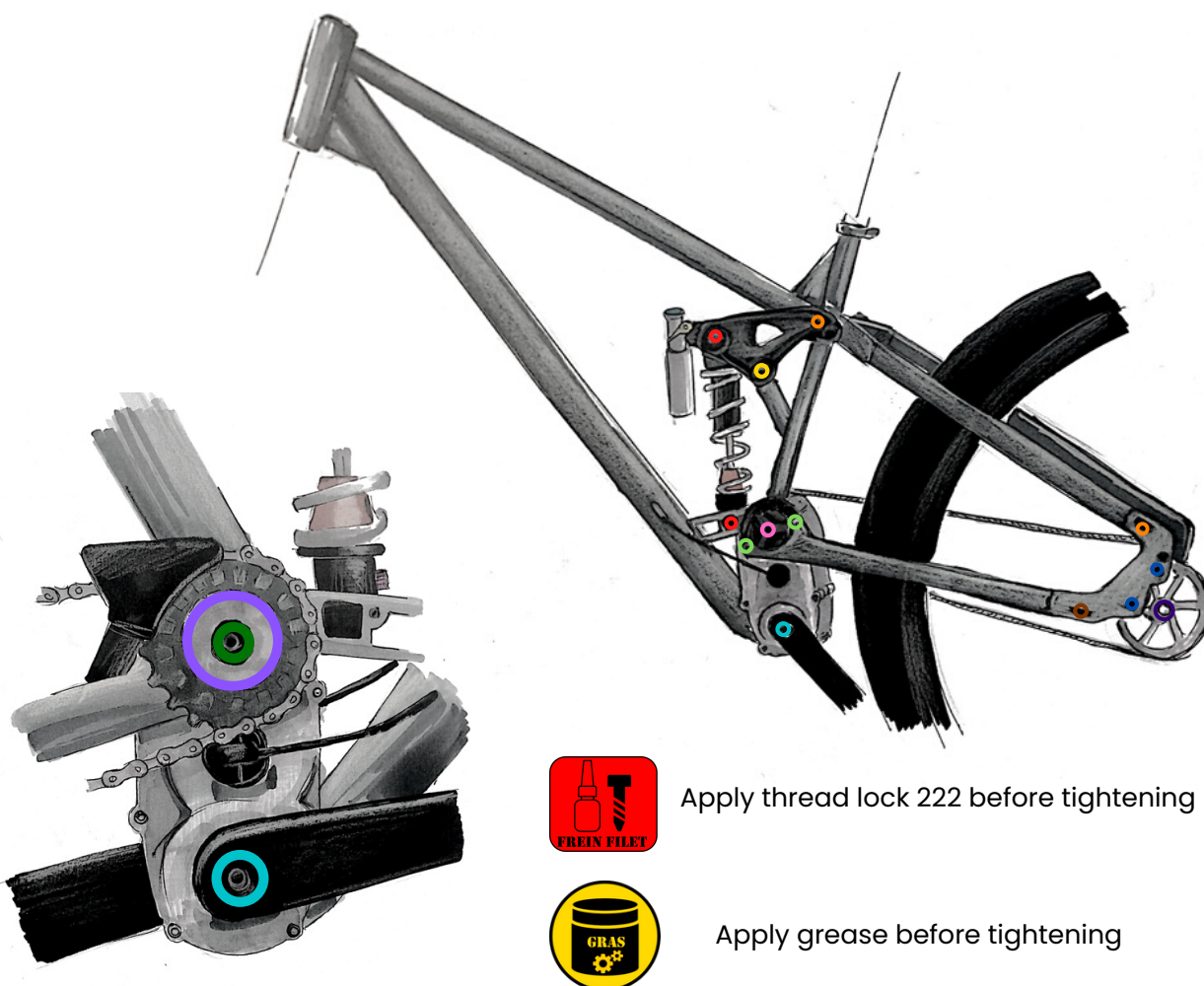

Apply thread lock 222 before tightening



Apply grease before tightening

	Screw designation	Tightening torque (Nm)
	Shock absorber (x3)	9 Nm
	Seat stay (x4)	8 Nm
	Low rocker axle (pivot point)	12 Nm
	GB output cover	10 Nm
	Swinging arm / GB bearing	Contact (rear) / 6Nm (front)
	Crank	20/25 Nm
	Dropout (Caliper) (x1)	3 Nm
	Dropout (x4)	8 Nm
	Front sprocket nut	30 Nm
	Front sprocket	20 Nm
	Rear wheel axle	10 Nm

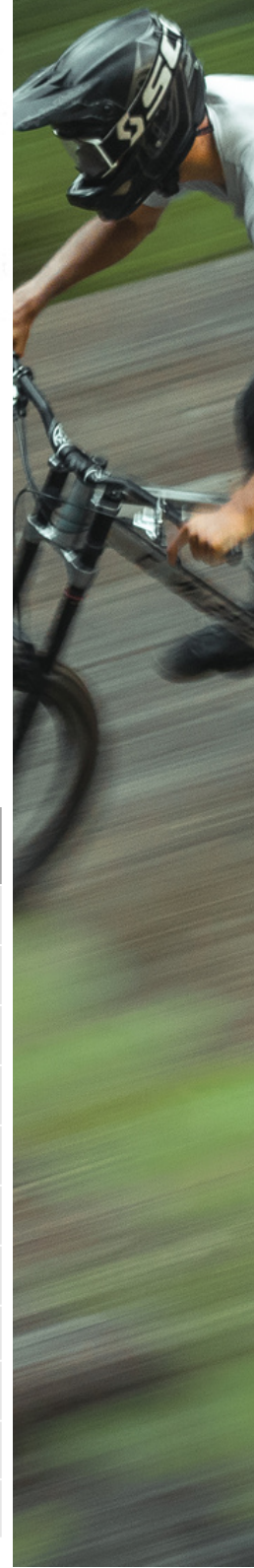

Cables explained

the cable routing is almost fully external. Please leave it as it is. Do not drill holes on the frame and try to run cables internally.

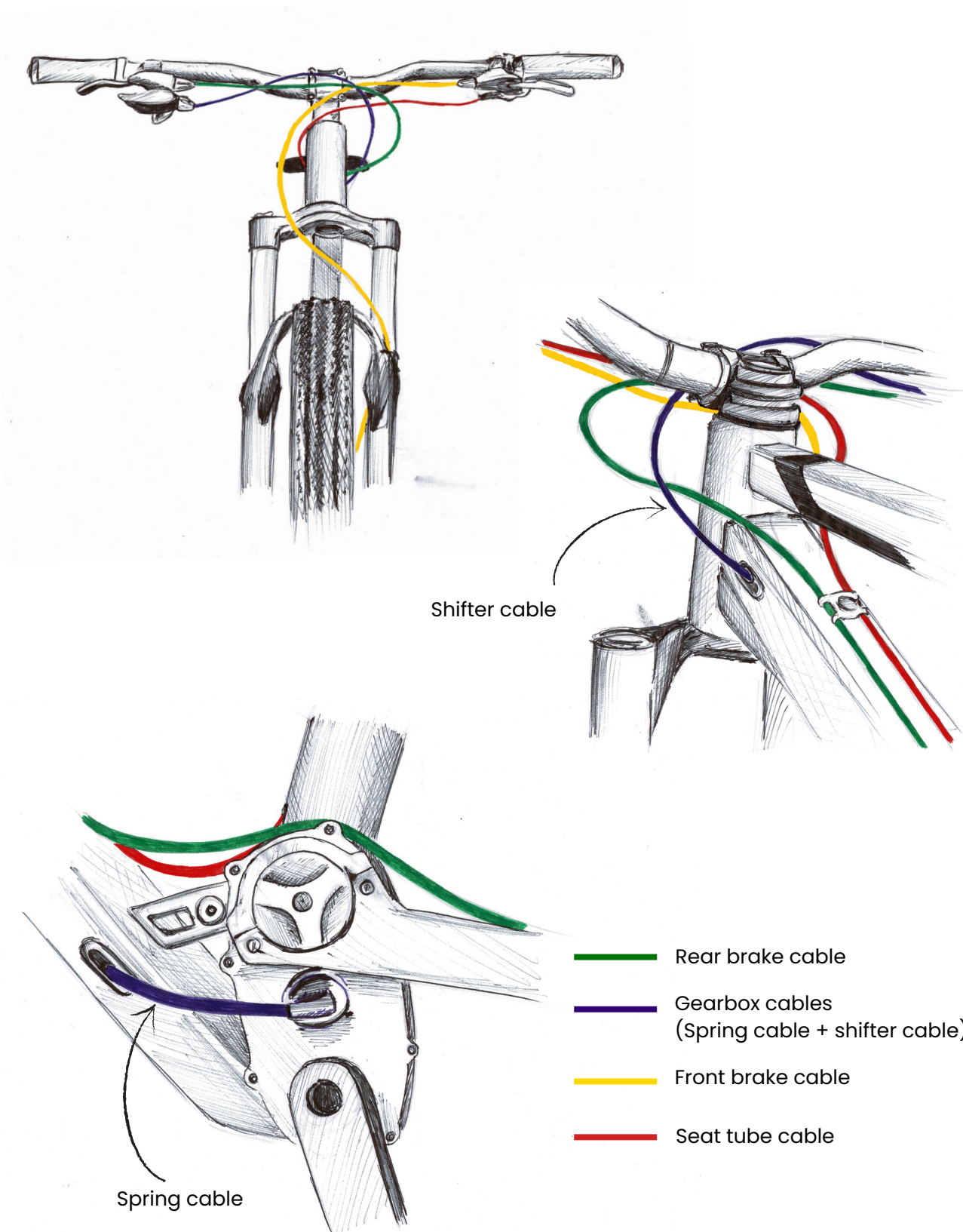

Sprocket replacement

Front sprocket :

Untighten

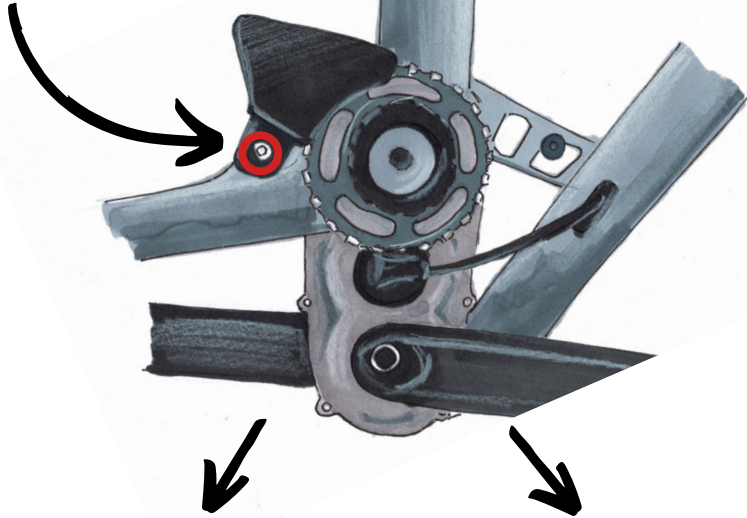

Belt transmission
Unthightening

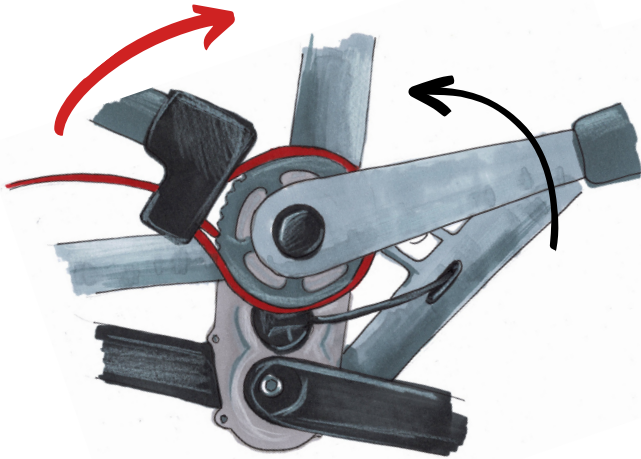

Chain transmission
Untightening

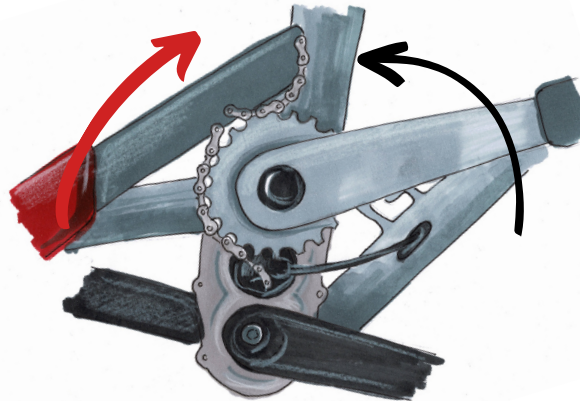

Tightening

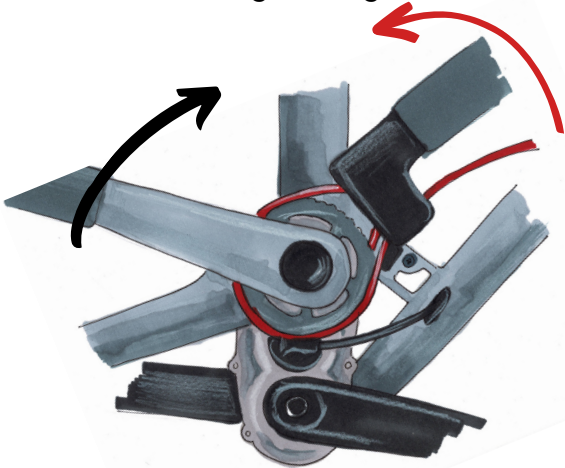

Tightening

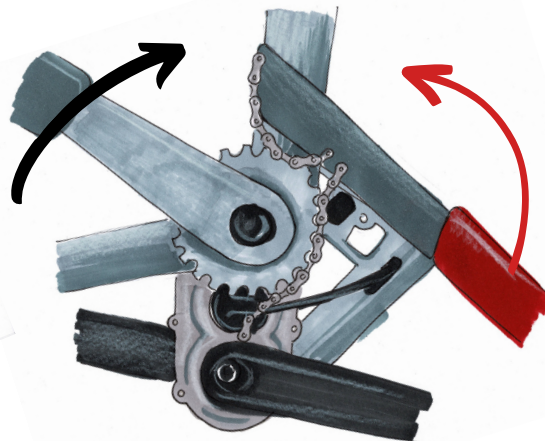

Rear sprocket:

Belt transmission
Untightening

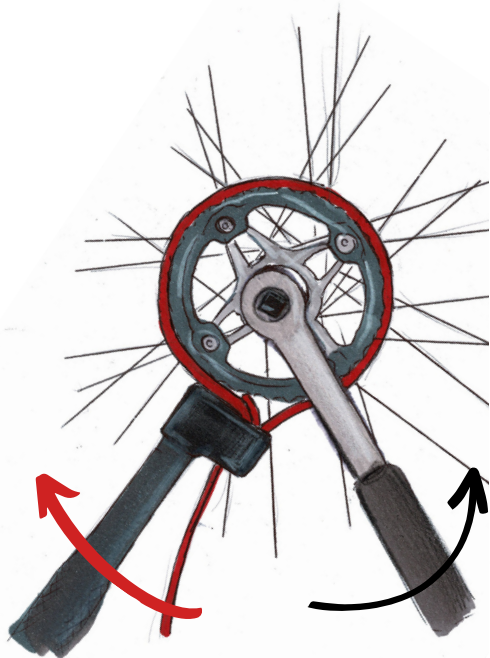

Tightening

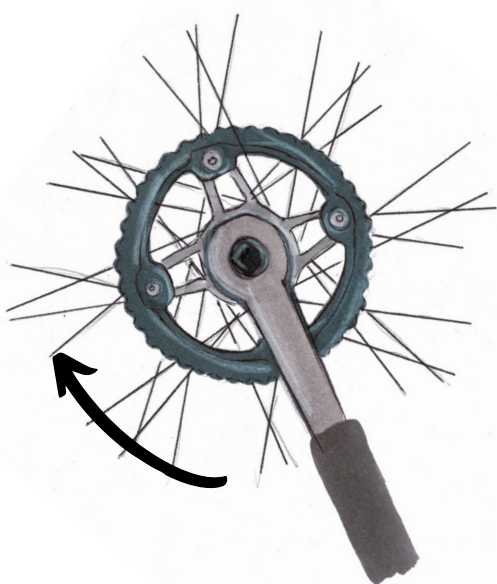

Chain transmission
Untightening

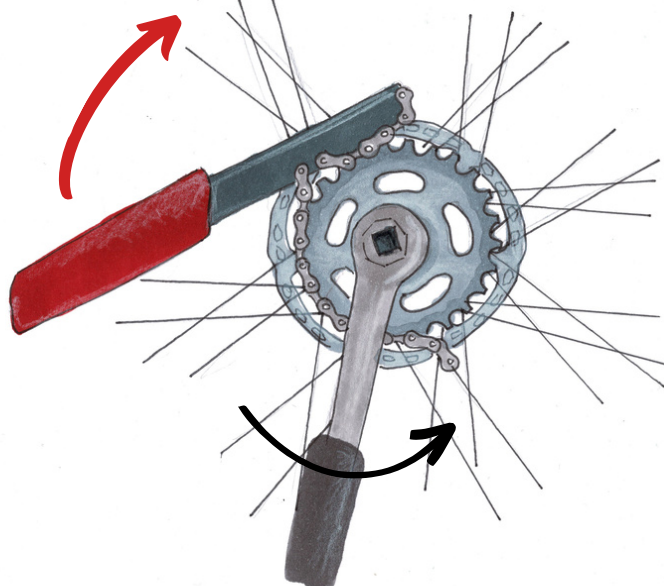

Tightening

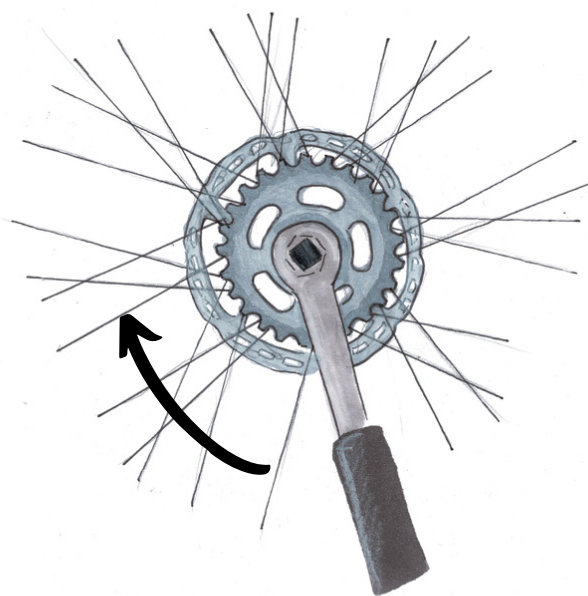

Rear wheel tension

It is very important to correctly set the tension and centering of the rear wheel.

A lower than ideal tension can cause derailments.

An higher than ideal tension will reduce efficiency and deteriorate bearings.

A bad wheel centering will deteriorate the gearbox's bearings and may damage the frame.

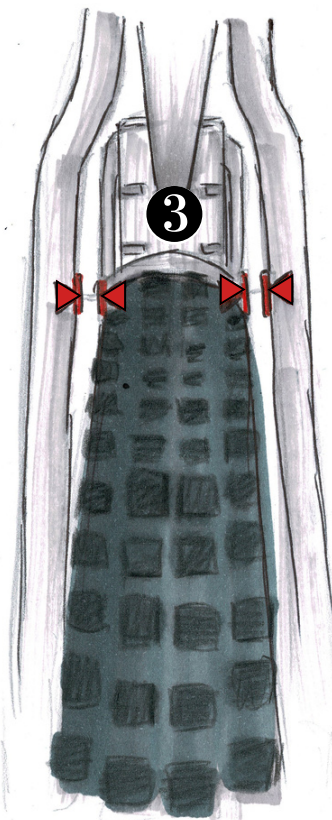
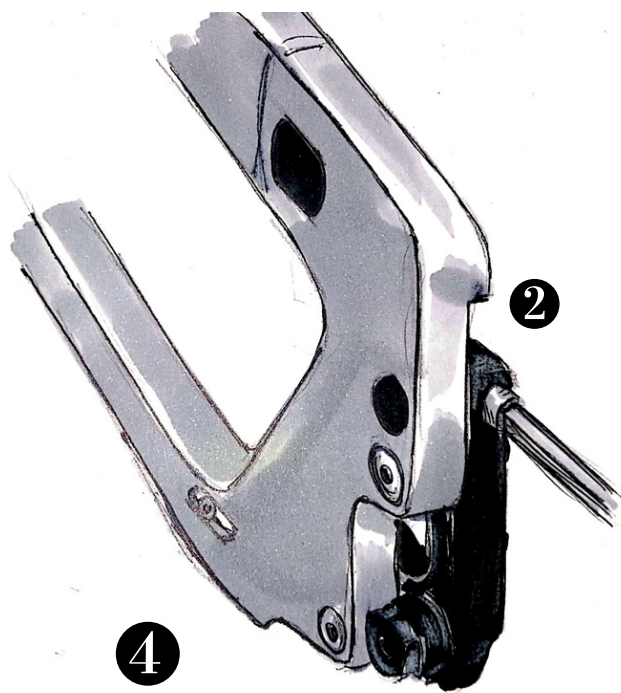
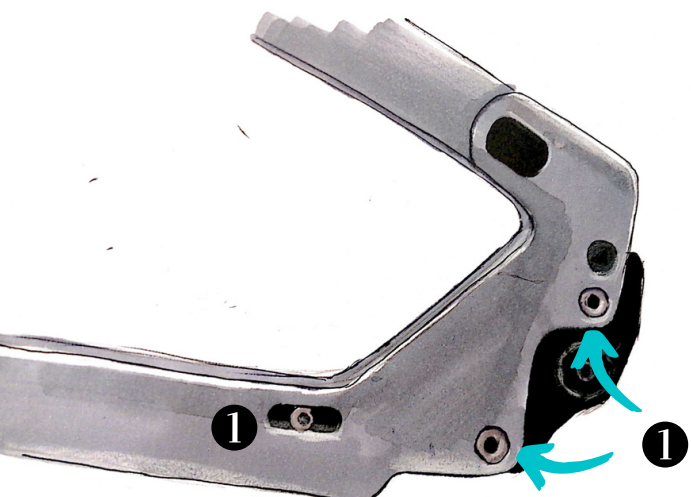

4

- 1 Unscrew the 5 screws
- 2 Set a proper chain/belt tension
- 3 Check for a good rear wheel centering
- 4 Tighten the 5 screws with the adequate torque (page 9)

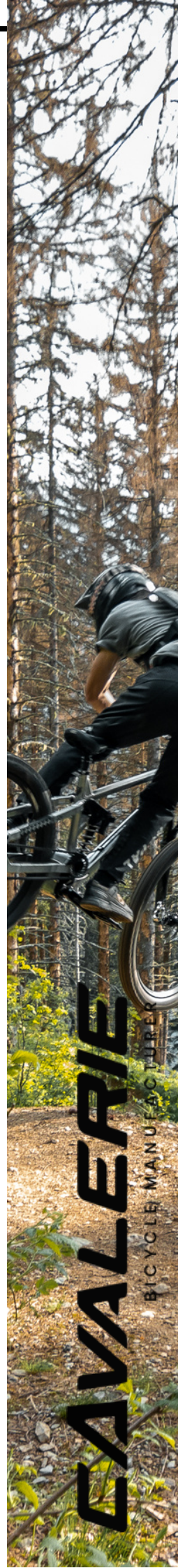

Shifter setup

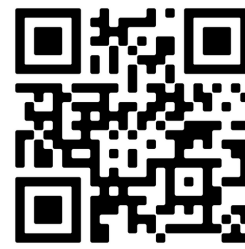

 Scan me

Cable replacement

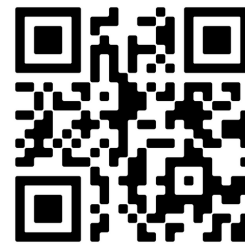

 Scan me

For more videos :



Effigear - Cavalerie bikes

Effigear designs and produces bicycle gearboxes. Our philosophy: "Designed to ride, built to last."

 YouTube



 Scan me



Gearbox maintenance

Before the first ride, do not forget to fill up the gearbox. Fill in the full oil flask (100ml) through the drain hole.

Use the Allen key shipped with the bike to remove the drain plug.

Riding without oil inside of the gearbox will damage it and suppresses warranty.

The first oil change must be done after **500km**.

Always fill in with new oil flask provided by Effigear.

Once the gearbox has ran-in, perform an oil change **every 5000km**.

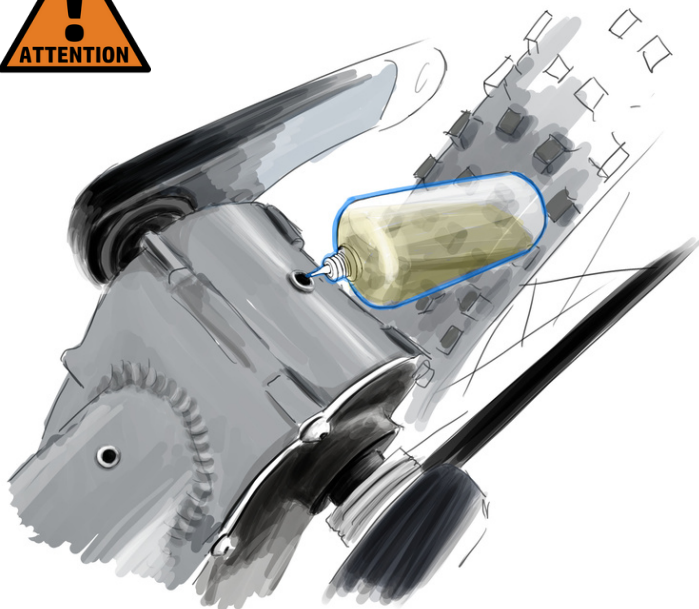

In case of any malfunctions with the gearbox :

- Check the shifter setup
- Contact us by email : contact@effigear.com



In any case you should try to open the gearbox yourself without permission !

Bike maintenance

You can find replacement parts for your bike on www.cavalerie-bikes.com
Or contact us by email : contact@effigear.com

The bike maintenance can be performed at any mechanic bike shop.

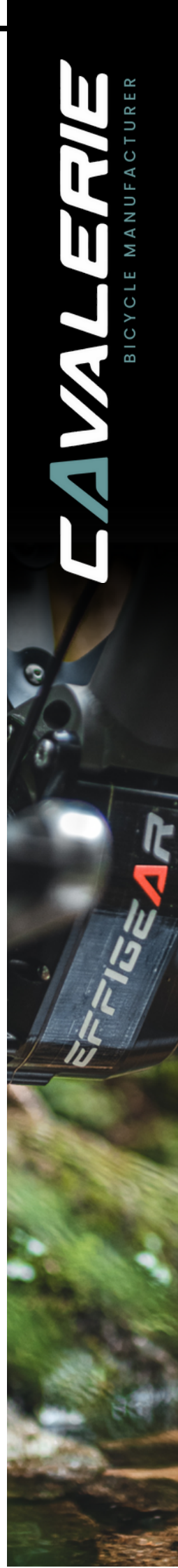

Maintenance timing

Before every session	Weekly	Monthly	Every 3 months	Annually
Check that the frame and fork do not show sign of fatigue : scratches, cracks, bumps, deformations, discolorations. Inspect the seat stay protection and ensure that it is fixed.	Check that the bolts are tightened according to the required specs and torques. Make sure to include every accessory ranging from pedals to b.	Verify the shifting cable and brake cable wear and tear.	Inspect the transmission for wear.	Yearly bike maintenance : Revise and inspect the frame and every component. Repair or replace parts if needed.
Check that the wheels are in good condition.	Check the rims and spokes.	Check that the cranks are tightened according to the required specs and torques.	Inspect the cranks and pedals.	Deep clean and lube of every components recommended by your bike mechanic.
Check the tires pressure.	Clean the bike.	Verify that your helmet is properly adjusted.	Verify the tires watertightness.	
Check the brakes, including brake pads and conducts.	Check the tires for wear and tear.	Verify belt/chain tension.	Inspect suspension components for wear.	
Verify that the wheels are properly fixed.	Clean the anti-dust joints on the suspension.			
Verify that the handlebar and stem are correctly positioned. Check for any stress sign : scratches, cracks, bumps, deformations and discolorations.				
Verify that the suspension parameters are set to your standards.				
Verify the lightning equipment and that the reflectors are in good condition.				
Verify that the saddle and seat post are correctly oriented and tightened.				
Check gear shifting fluidity and proper functioning.				
Lube the chain.				

Here are a few guidelines, but they do not constitute a complete inspection. Following these guidelines will help maintaining the performance of the bike and prevent issues. It is important to keep in mind that maintenance can vary with factors like climate, trail condition and frequency of use. For more informations on specific components, please visit the manufacturer's website. If you have any issue with your bike that you are not able to solve, bring your bike to a maintenance approved bike shop.

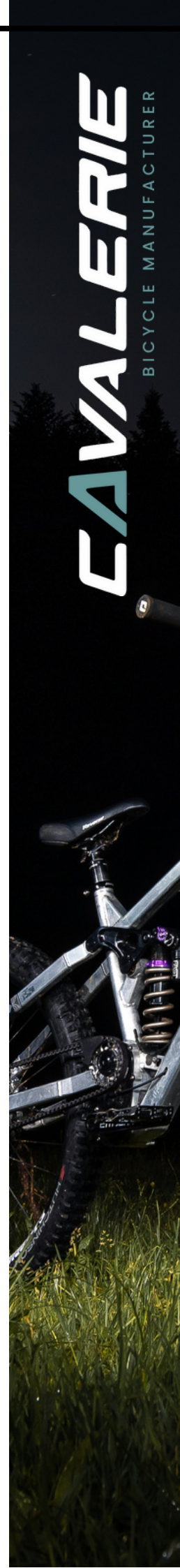

Rear travel change

Spring shock absorber :
Remove and replace the washers.

Air shock absorber :
Contact the shock company.

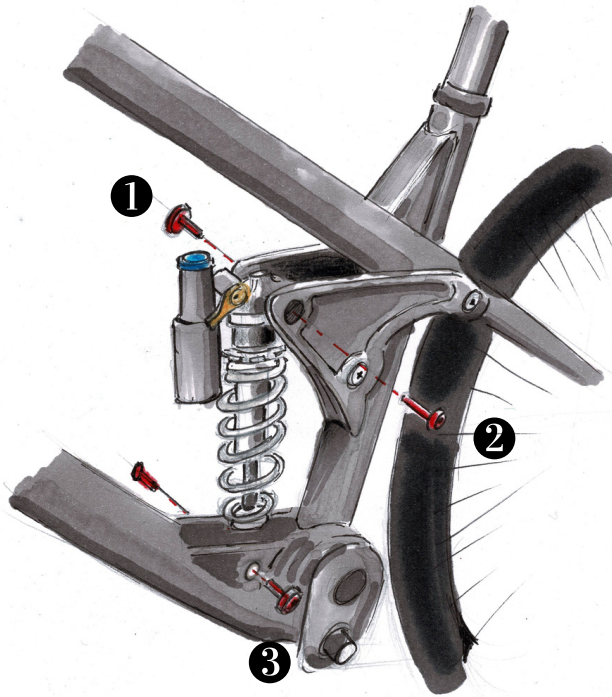
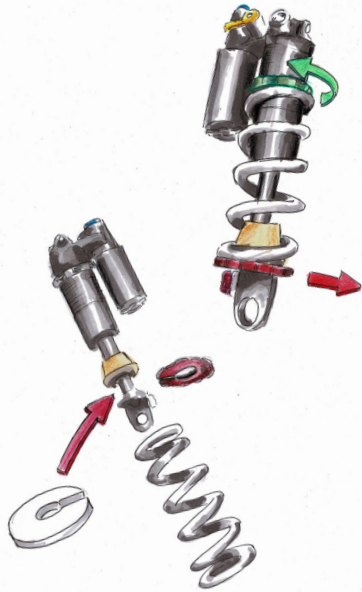

Rear wheel size change

To change the rear wheel size, you must change the dropouts (shown below).
Do not change wheels without replacing the plates as the bike is not designed for that.

Wheel plates are available on the Cavalerie bikes website or contact us by email.

27,5"



29"



CAVALERIE
BICYCLE MANUFACTURER

CAVALERIE® bikes are products destined to give its customers the best satisfaction. In this regard, we provide warranty for all bikes commercialized.

Warranty period

CAVALERIE® guarantees its products for manufacturing or material defects for a period of :

- + Anakin in a non competitive use for a 2 years duration.
- + The entire collection of components sold with your CAVALERIE® bike are also tied with the brand's warranty.
- + The finishing touches, paints, stickers and other decorations are guaranteed for manufacturing defects for a 6 months duration.
- + The EFFIGEAR® gearbox is guaranteed for 5 years except for wear parts.

Guaranteed parts:

- Pinions
- Pawls
- Carter
- Covers
- Inner bearings
- Seals and gaskets
- Crank shaft
- Shifting shaft
- Output shaft
- 9 splines spider
- Shifting shuttle
- Spring assembly
- Shifter assembly

Gearbox wear parts :

- GB cables
- Cable sheaths
- Cranks
- Sprocket
- Outer bearings

The bike and gearbox must be cleaned before being sent back to CAVALERIE®. If returned dirty, CAVALERIE® reserves the right to charge the customer a cleaning fee of 35.00 including VAT at the legally applicable rate.



CAVALERIE
BICYCLE MANUFACTURER

Warranty chart

During the warranty period, CAVALERIE® agrees to replace free of charge and at its discretion, the frame and parts CAVALERIE® that have a manufacturing or material defect in the following conditions.

The defect must be assessed by the CAVALERIE® engineering office. In that matter, only they are entitled to decide on the implementation of a warranty.

In the occurrence of a re-sell before the end of warranty, it will transfer to the next buyer.

The bike lifespan will vary according to its build and material used. Nevertheless, poor maintenance, intense use with heavy loads during competitions or uses others than it was designed for, will greatly diminish the bike lifespan or can cause premature and accidental breaks that can void warranty.

In this matter, the CAVALERIE® warranty **will not apply** in the following cases :

- + Damages caused by normal wear and those caused by material fatigue.
- + If the bike is used beyond its intended purpose and technical specifications, or in case of abnormal or excessive use cases (poor SAG setup on the shock absorber or fork)
- + In case of non-compliance with user guidelines mentioned in the product manuals.
- + If poor maintenance is found, or any sign of negligence from the buyer. Regular maintenance must be done by a specialized mechanic. For this reason, maintenance and service fees do not fall within the scope of the CAVALERIE® warranty.
- + if the bike has been used in a competitive event.
- + In case of an accident, fall or crash.
- + In case of any modification done to the bike or to its specs (frame painting, frame polishing, frame drilling, change in geometry, use of components that are not initially intended for the bike or not adapted) that is not explicitly approved by CAVALERIE®.
- + If the bike is not adapted to your morphology.
- + If you have continued using your bike knowing the bike was damaged.
- + If the bike has been damaged as a result of an intentional fault or involving the responsibility of a third party.
- + In case of impact of external elements or agents (natural disaster, fire, humidity...)
- + In case of a usage non conforming with security norms.
- + In case of a commercial use (rental).
- + Opening of the gearbox without the consent of CAVALERIE®
- + Use of an oil different from the one supplied by CAVALERIE®
- + Bike theft

Ride smart and hard!

The Cavalerie bike / Effigear Team